

HE 5422 MR

Differential pressure regulator with measuring hose cleaning



Operating manual

Translation of the operating manual
(Original version German)

HESCH

AUTOMATION PARTNER

Imprint

HESCH Industrie-Elektronik GmbH
Boschstraße 8
D-31535 Neustadt
Germany
Phone +49 (0) 5032 9535-0
Fax +49 (0) 5032 9535-99
Internet: www.hesch.de
E-Mail: info@hesch.de

District court Hanover
HRB 111184
Tax-No.: 34/200/22524
VAT No.: DE813919106

Management:
Walter Schröder, Werner Brandis
Publisher:
HESCH Industrie Elektronik GmbH, Documentation Department

Copyrights



© Copyright 2014 HESCH Industrie-Elektronik GmbH. All rights reserved. The content including pictures and the design of this manual are subject to copyright protection and other laws for protection of intellectual property. The dissemination or alteration of the content of this manual is prohibited. Moreover, these contents may not be copied, disseminated, altered or made accessible to third parties for commercial reasons.

Table of contents

1	Foreword	4
1.1	Information regarding the usage of these operating instructions	4
1.2	Legal provisions	6
2	Safety information	7
2.1	Symbols and basic safety information	7
2.2	Safety during the individual phases of operation	9
3	Device description	11
3.1	Overview	11
3.2	Display and control elements	12
3.3	Differential pressure column	13
3.4	Technical data	14
4	Installation	16
5	Electrical commissioning	17
5.1	Safety notes	17
5.2	Supply voltage	18
5.3	Connection diagram	19
5.4	Inputs	19
5.5	Outputs	19
6	Parametrization	20
6.1	Parametrization using device keyboard	20
6.2	Offset for zeroing	23
6.3	Parametrization using the Service-PC	23
6.4	Parameter protection	23
6.5	Reset of factory settings	24
7	Operation	25
7.1	Normal operation	25
7.2	Testing function	27
7.3	Differential pressure measurement	27
7.4	Measuring hose cleaning	29
8	Error messages	30
9	Declaration of conformity	31
10	Maintenance and service	32
10.1	Notes	32

1 Foreword

1.1 Information regarding the usage of these operating instructions

Structure

Chapter 1	Foreword Information on chapter structure, document history, intended use and device safety.
Chapter 2	Safety information Important safety information regarding the Differential Pressure Regulator.
Chapter 3	Device description Description of the Differential Pressure Regulator, control elements and technical specifications.
Chapter 4	Installation Dimensions of the device and scope of delivery.
Chapter 5	Electrical commissioning Connection of supply voltage and signals.
Chapter 6	Parametrization Parametrization on the device or with a service PC.
Chapter 7	Operation Information regarding operation, differential pressure measurements, measuring hose cleaning and error messages.
Chapter 8	Error messages Information regarding error messages that are shown on the display and indicated by the flashing LEDs.
Chapter 9	Declaration of conformity
Chapter 10	Maintenance and service Information regarding control operations and disposal

Target group

These operating instructions are intended for qualified electricians that will install, wire, commission and parametrize the HE 5422 MR Differential Pressure Regulator.

Document history

Date / Version	Description
10/2013 / 1.0	First creation
04/2014 / 1.1	Chapter 3.1, 3.4, 5.2, 5.3: Changed value for wide-range power supply (100 – 240 VAV). Chapter 2.2: Changed value for surface temperature. Chapter 6.1: Supplemented factory setting of Δp -Measuring-range (mbar). Chapter 9: Added declaration of conformity. Chapter 8: Added error message (E 4).
03/2019 / 1.2	Chapter 3.4 Technical data: Operating temperature in EX zone added.

1.2 Legal provisions

Manufacturer

HESCH Industrie-Elektronik GmbH, Boschstraße 8, D-31535 Neustadt, Germany

Intended use

- The HE 5422 MR Differential Pressure Regulator serves the purpose of measuring the differential pressure using filter elements as part of the industrial fabric filter technologies and to operate a valve control unit. The differential pressure is monitored by two alarm thresholds.
- The control unit can be operated within the usage and ambient conditions stated in this manual without causing any safety risks.
- The manufacturer is not liable for improper usage and the resulting personnel injuries or damage; the risk lies entirely with the operator. Failure to comply with the above mentioned criteria regarding intended use may void the warranty – the manufacturer cannot be held liable for damage to the device in this case.

Personnel qualification

Only qualified electricians with the appropriate knowledge in the field of electrical engineering are allowed to conduct any work on the Differential Pressure Regulator.

Device safety

The device was built and tested in accordance with VDE 0411 / EN 61010-1 and has left the factory in an operationally safe condition. In order to maintain this condition and to ensure safe operation, the user has to follow the instructions and warnings contained in this manual, see chapter 2 "Safety information" on page 7.

2 Safety information

2.1 Symbols and basic safety information

This chapter contains important safety provisions and information. In order to protect against personnel injury and damage, it is necessary to carefully read this chapter before working with the device.

Used symbols

The following symbols are used in this manual. All safety information notes are structured in a uniform manner.



Warning of personnel injury!

The severity of the danger is indicated by the respective signal word, see page 8.



Warning of explosive atmosphere!



Warning of dangerous electrical voltage!



Warning of material damage due to electrostatic charging!



Warning of material damage!



Note!

Indicates possible malfunctions and provides information regarding optimal operating conditions.

Signal words

DANGER!

Indicates an immediate danger with *high* risk that will result in death or serious injury if not avoided.

WARNING!

Indicates a possible danger with *medium* risk that may result in death or serious injury if not avoided.

CAUTION!

Indicates a danger with *low* risk that might result in slight or moderate injury if not avoided.

Structure of warning notes

All warning notes in these operating instructions are structured in a uniform manner. The pictogram designates the type of danger.



SIGNAL WORD!

An informative text describes the danger and suggests how it can be avoided.

2.2 Safety during the individual phases of operation

The following safety notes must be observed when installing the device and during operation.



Danger of electric shock!

Disconnect the power supply before working on the device. Install the electrical lines in accordance with the respectively applicable local regulations (VDE 0100 in Germany). Lay the measuring lines separately from the power lines. Produce a connection between the protective ground connection (in the respective device carrier) and a protective ground.



Danger of electric shock!

Any interruption of the protective ground in the device carrier may cause the device to become dangerous. Deliberate interruptions are not permissible. If it can be assumed that safe operation is no longer possible, then the device shall be put out of commission and be secured against unintended operation or re-activation.



Danger of electric shock!

Do not open the device under voltage! When opening the devices or removing covers and parts, live parts may become exposed. Connecting points may also be live!



Caution!

The device may not be put into operation when there is visible damage on the device.



Caution!

Observe the accident prevention regulations applicable to the system, such as BGV A 3 "Electrical Systems and Equipment" during installation, commissioning, maintenance and troubleshooting.



Caution!

Clean soiled contacts using oil-free compressed air or spirit and a lint-free cloth.



Material damage due to electrostatic charging!

Observe the safety measures according to DIN EN 61340-51/-3 in order to prevent electrostatic discharging!



Electrical connection!

Install the electrical lines in accordance with the respectively applicable local regulations (VDE 0100 in Germany). Lay the measuring lines separately from the power lines. Produce a connection between the protective ground connection (in the respective device carrier) and a protective ground.



Explosion protection!

The device is suitable for operation in explosion zone 22 with the lid closed. Prior to opening the device, it has to be ensured that there are no explosive ambient conditions, such as dust development.

The device is marked with:

CE  II 3D T135°C IP65

Ex tD A22 IP65 T135°C

 II 3D tc IIIB T135°C Dc

II Not suitable for mines susceptible to firedamp

3D Dusts, normal safety

T135°C Surface temperature

IP65 Protection class: dust-proof, scoop-proof



Troubleshooting!

When beginning to troubleshoot, all possible sources of error regarding additional equipment or cables (measuring cables, wiring, slave devices) should be taken into consideration. If no error source can be found after examining these points, we recommend to send the device to the supplier.



Decommissioning!

Disconnect the power supply entirely if the device is to be decommissioned. Secure the device against inadvertent operation!

If the device is interconnected with other devices and/or equipment, the effects of the deactivation should be considered prior to disconnecting the device and the appropriate precautions should be taken beforehand.

The following provisions must be observed:

- Attach the cables to the cable glands correctly.
- Provide unneeded housing bores with locking bolts.
- It is only permitted to clean the housing with wet cleaning agents in order to avoid static charging.
- It is required to clean the device in order to prevent increased dust formation.

3 Device description

3.1 Overview

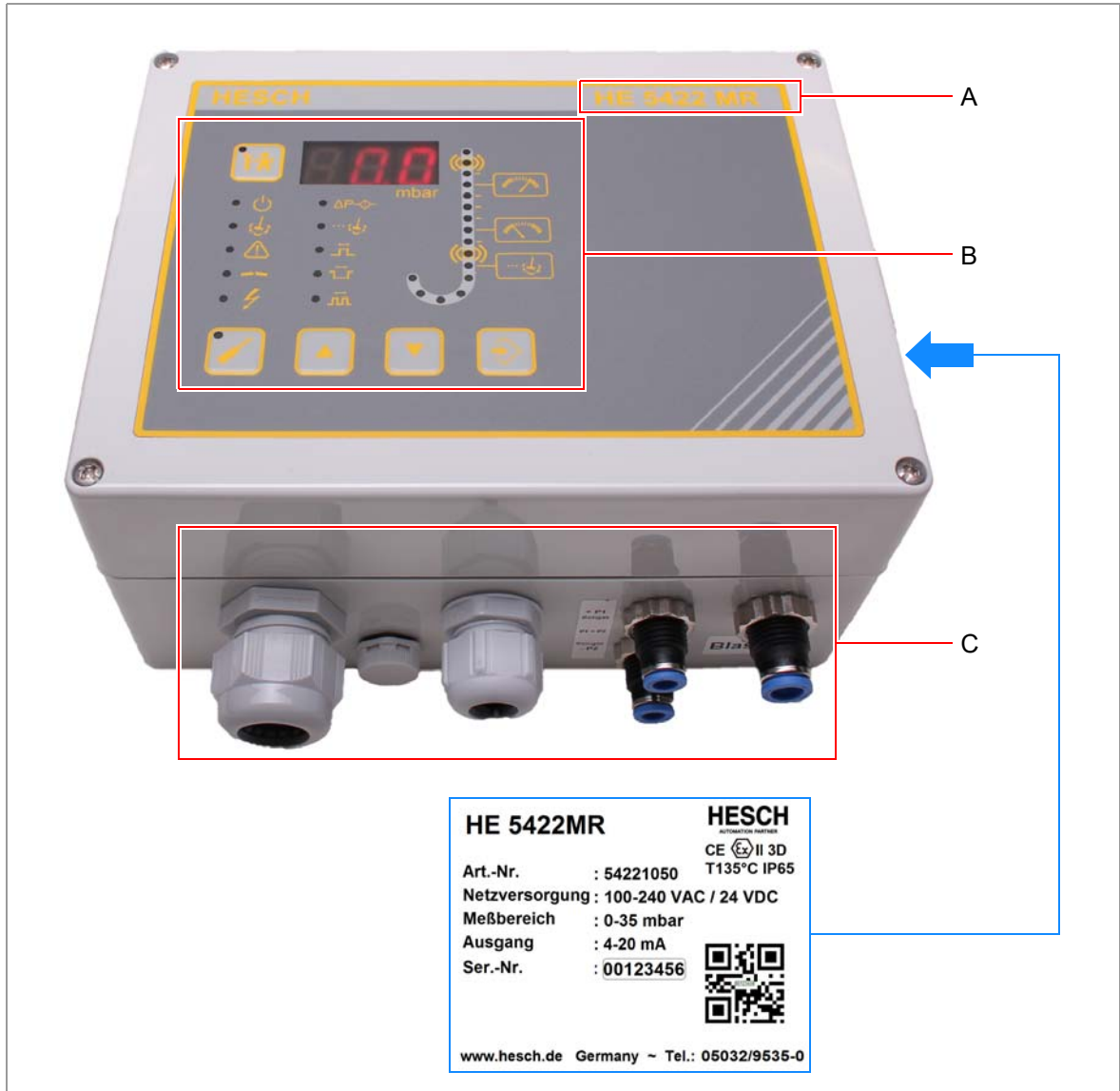

Fig. 3.1: Overview

- A. Type designation
- B. Display and control elements
- C. Cable glands

3.2 Display and control elements

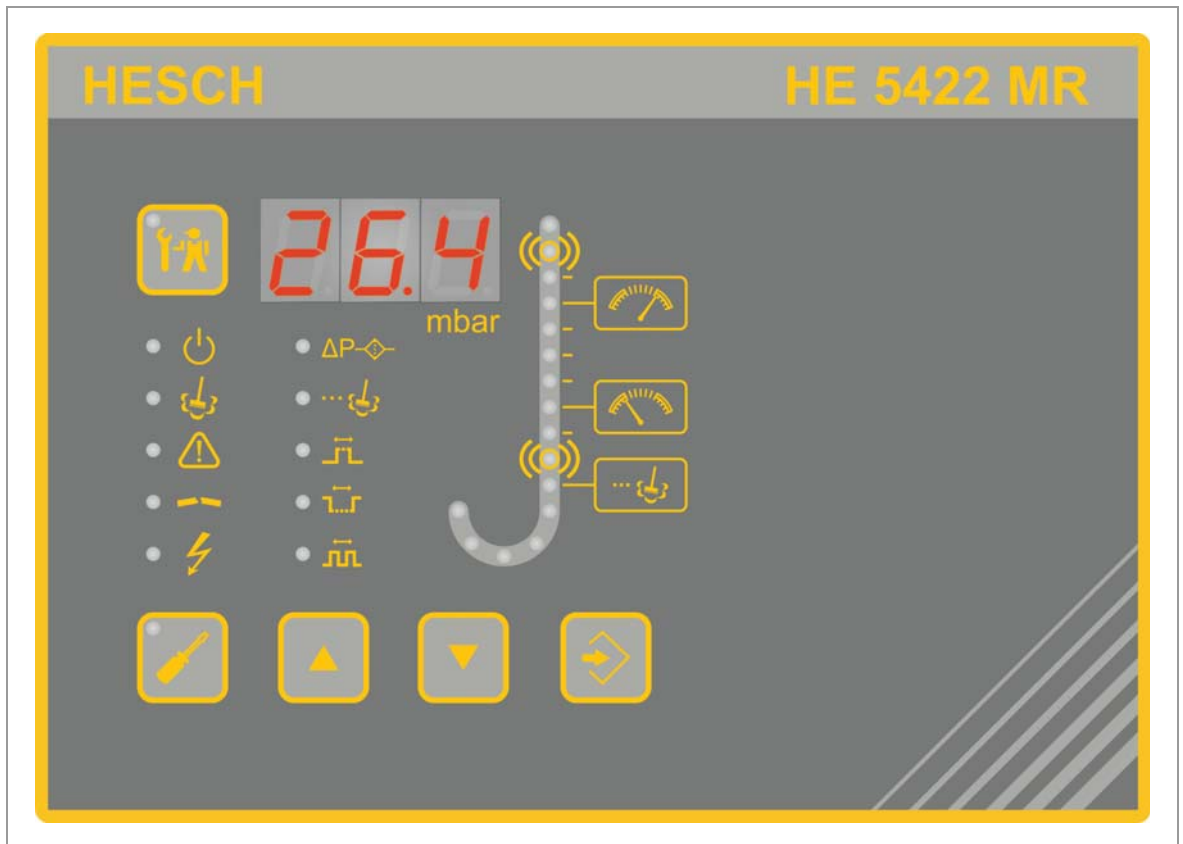









Fig. 3.2: Display and control elements

Symbols	Meaning
	Operation message
	Cleaning active
	Alarms active
	Interruption on one valve
	Short-circuit of a valve (over current)
	Filter constant of the differential pressure measurement
	Post cleaning time <ul style="list-style-type: none"> • Normal operation: LED lights up when post cleaning is active • Parametrization mode: LED flashes when the parameter can be selected
	Blowing time: opening time of the blow air valve

Symbols	Meaning
	Recovery time: delay to restore the pressure balance after the blowing time
	Interval: waiting time until the next measuring line cleaning cycle
	TEST button: testing mode ON/OFF
	PARAM button: parametrization mode ON/OFF
	UP button: increase displayed value
	DOWN button: reduce displayed value
	ENTER button: accept/confirm displayed value
	Display: <ul style="list-style-type: none"> • Normal operation: current differential pressure • Parametrization mode: parameter values • Alarm indications

3.3 Differential pressure column

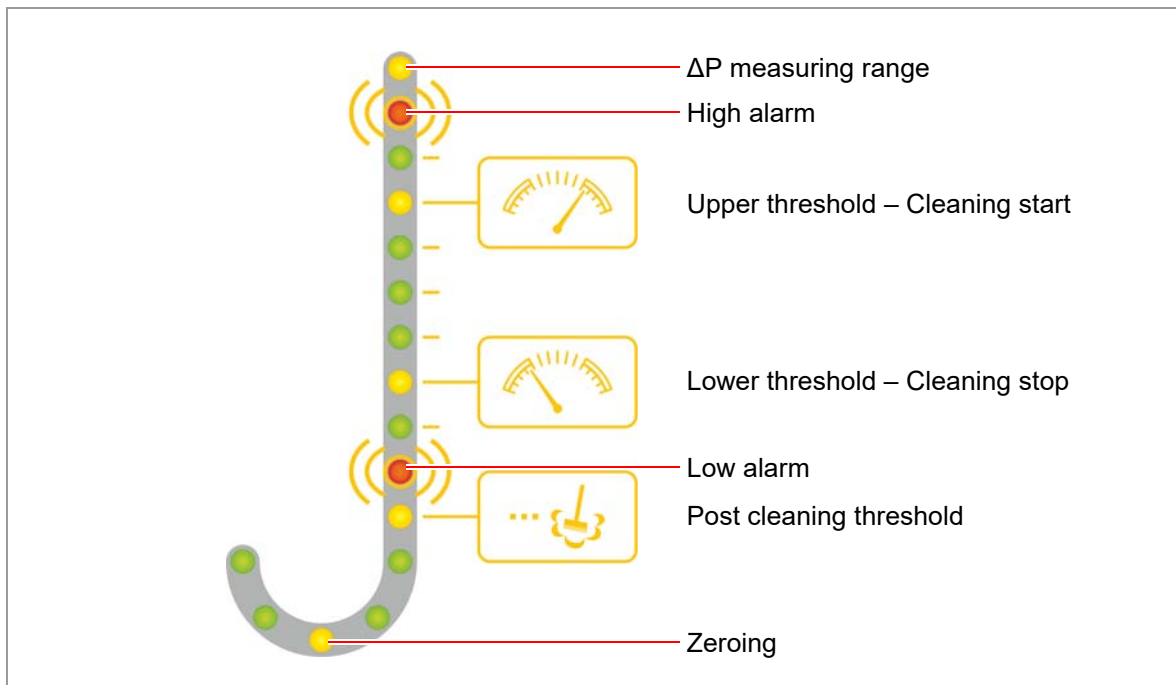

Fig. 3.3: Differential pressure column

In normal operating mode, the LEDs serve the purpose of displaying the differential pressure.

In parametrization mode, the selected parameter value is indicated by flashing.

3.4 Technical data

Technical data	
Measuring range:	Maximum of 35 mbar (90 or 450 mbar on request)
Maximum differential pressure:	160 mbar
Basic accuracy:	± 1% of final value
Temperature drift:	± 0.05% / K of final value
Hysteresis:	± 0.5% of final value
Intended use:	Differential Pressure Regulator with integrated Measuring Hose Cleaning used to control the cleaning of industrial filtration plants
Supply voltage:	<ul style="list-style-type: none"> • 100 – 240 VAC ±10% • 24 VDC ±10%
Power consumption:	Max. 30 W
Display:	7-segment display, 3 digits, 14 mm high, red for differential pressure display, parameter values and alarm messages
LEDs:	<ul style="list-style-type: none"> • 7 LEDs for status indications • 16 LEDs for differential pressure indications
Buttons:	PARA (ESC), UP, DOWN, ENTER, TEST
Analogue output:	<ul style="list-style-type: none"> • 4...20 mA • Galvanically isolated • Max. permissible load: 400 Ω
Digital inputs:	Start, post cleaning. Internally supplied by 24 VDC / 1 mA
Relay outputs:	<ul style="list-style-type: none"> • 1 change-over contact 250 VAC, 5 A as a combined operating and fault indicator • 1 NO contact 250 VAC, 5 A as a cleaning indicator • 2 change-over contacts 250 VAC, 5 A as alarm indicators
Interfaces:	USB Device, Type B for reading and writing of parameters (USB / TTL adapter required)
Creepage distances and clearances:	<ul style="list-style-type: none"> • Contamination Class 2 • Over voltage Category II
EMV:	<ul style="list-style-type: none"> • Interference emission: DIN EN 61000-6-4 • Interference immunity: DIN EN 61000-6-2
Housing:	<ul style="list-style-type: none"> • ABS (acrylonitrile-butadiene-styrene) • IP65 Protection Class • Dimensions: 200 mm × 150 mm × 100 mm (W × H × D)
Cable glands:	<ul style="list-style-type: none"> • 1 x M25 with multiple sealing insert for 4 liens with 6 mm diameter • 1 x M20 for supply and communication
Electrical connections:	<ul style="list-style-type: none"> • Power supply: rigid/flex cross-section 2.5 mm²; flex.: max. 1.5 mm² with wire end ferrule • Rest: rigid/flex cross-section 1.5 mm²; flex.: max. 0.75 mm² with wire end ferrule

Technical data	
Pneumatic connections:	<ul style="list-style-type: none">• Pressure measuring line: 2 × push-in bulkhead connector for Ø6 mm hose• Blowing pressure connection: 1 × push-in bulkhead connector for Ø8 mm hose• Maximum blowing pressure: 8 bar
Installation:	Wall mounting, mounting position: vertical

Ambient conditions	
Climatic	
Storage	-20°C ... +70°C
Transport	-40°C ... +85°C
Operation	<ul style="list-style-type: none">• -20°C ... +50°C• in EX zone: -20 °C ... +40 °C
Relative humidity	Relative humidity 95%, no condensation allowed, KUF in accordance with DIN 40400

Subject to technical changes.

4 Installation

The ambient temperature at the installation position may not exceed the permissible temperature for rated use listed in the data sheet. The device may be installed in areas subject to the EX ATEX Zone 22 Explosion Class. The special provisions should be observed, see chapter 2.2 "Safety during the individual phases of operation" on page 9.

Dimensions

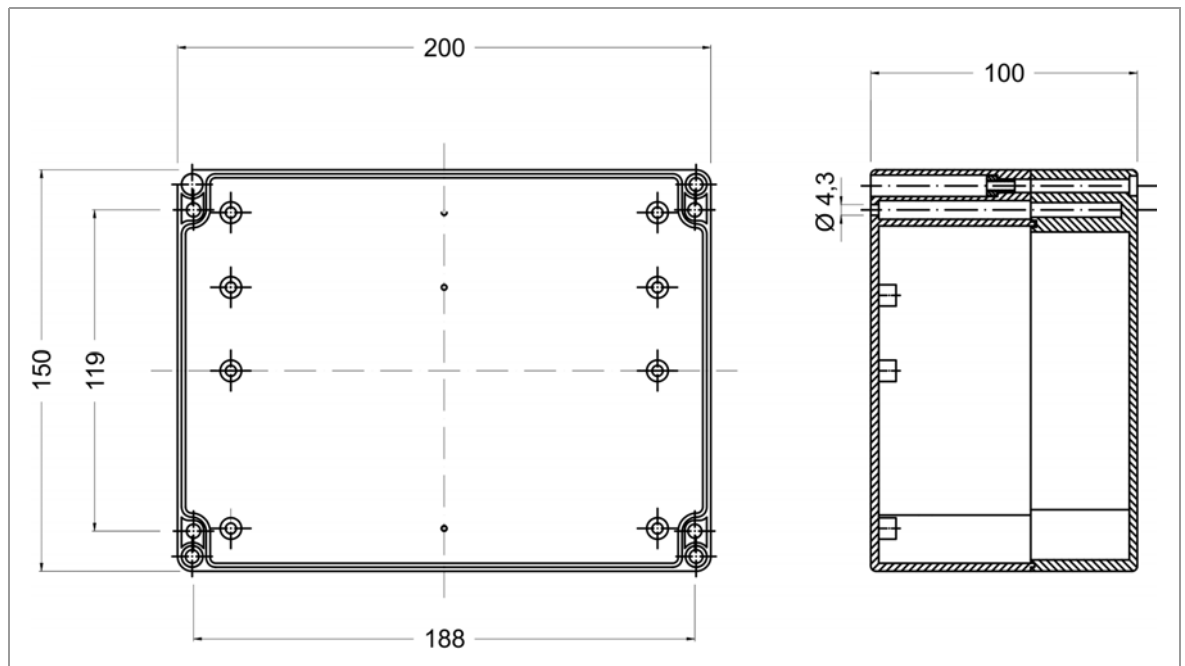

Fig. 4.1: Dimensions

Scope of delivery

- HE 5422 MR
- Operating Manual



Note!

After receiving the delivery, check it for completeness and obvious defects. In case of a complaint, immediately contact your local HESCH representative.

5 Electrical commissioning

Mind the following points prior to turning on the device:

- Firmly connect the cables to the glands. The supply voltage must match the specifications on the type plate.
- The device may only be operated in a closed state.
- The temperature limitations specified for use of the device have to be observed before and during operation.
- The protective ground connection in the appropriate device carrier has to be conductively connected to the protective ground

5.1 Safety notes



Danger of electric shock!

Only perform the electrical installation in a dead-voltage state.



Material damage due to electrostatic charging!

Observe the safety measures according to DIN EN 61340-51/-3 in order to prevent electrostatic discharging!



Note!

Only qualified specialists may work on the electronics.

5.2 Supply voltage

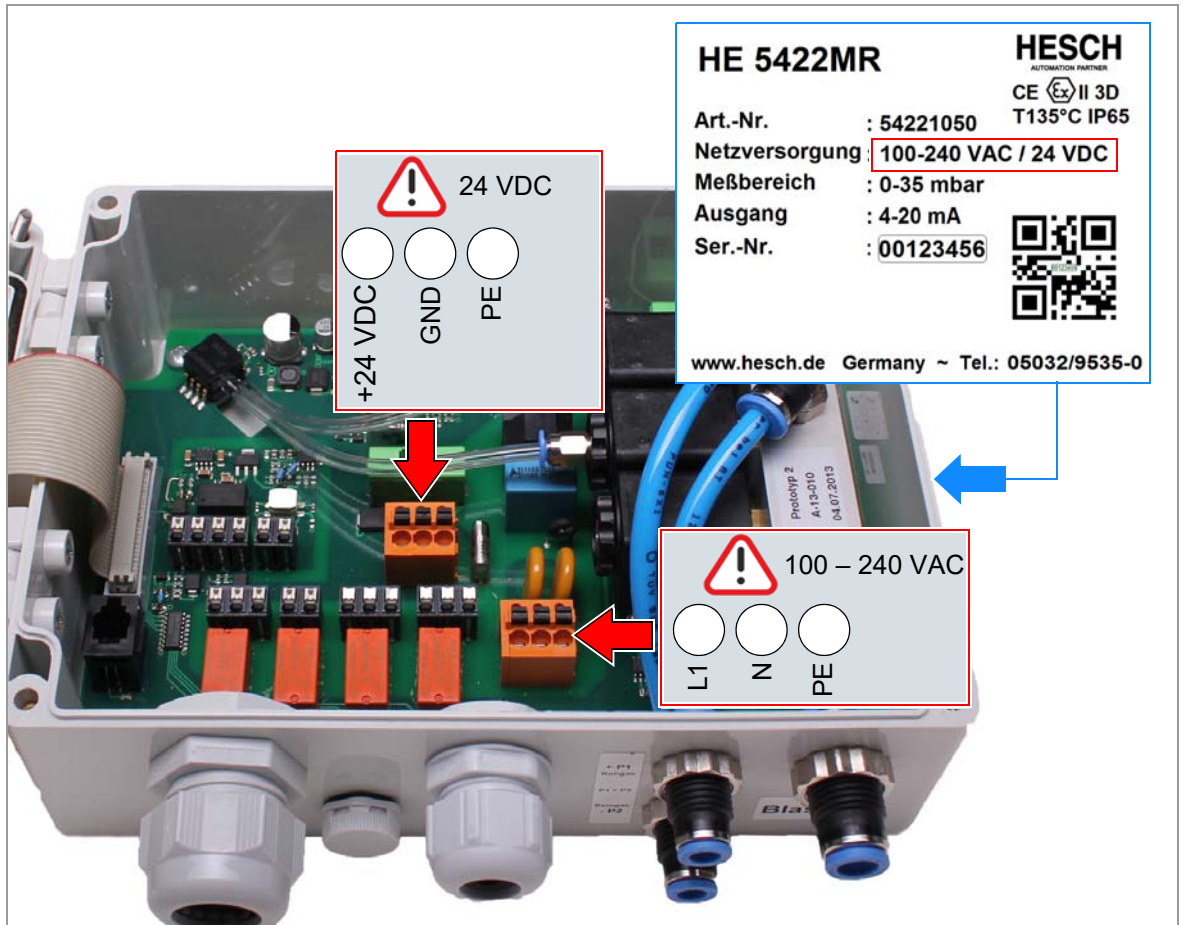

Fig. 5.1: Supply voltage

1. Loosen the screws on the housing cover (lid) and remove the cover.
2. Read the supply voltage value off the type plate (for example 100 – 240 VAC and 24 VDC mains voltage).
3. Connect PE conductors.



Note!

Both supply voltages may be connected at the same time.

5.3 Connection diagram

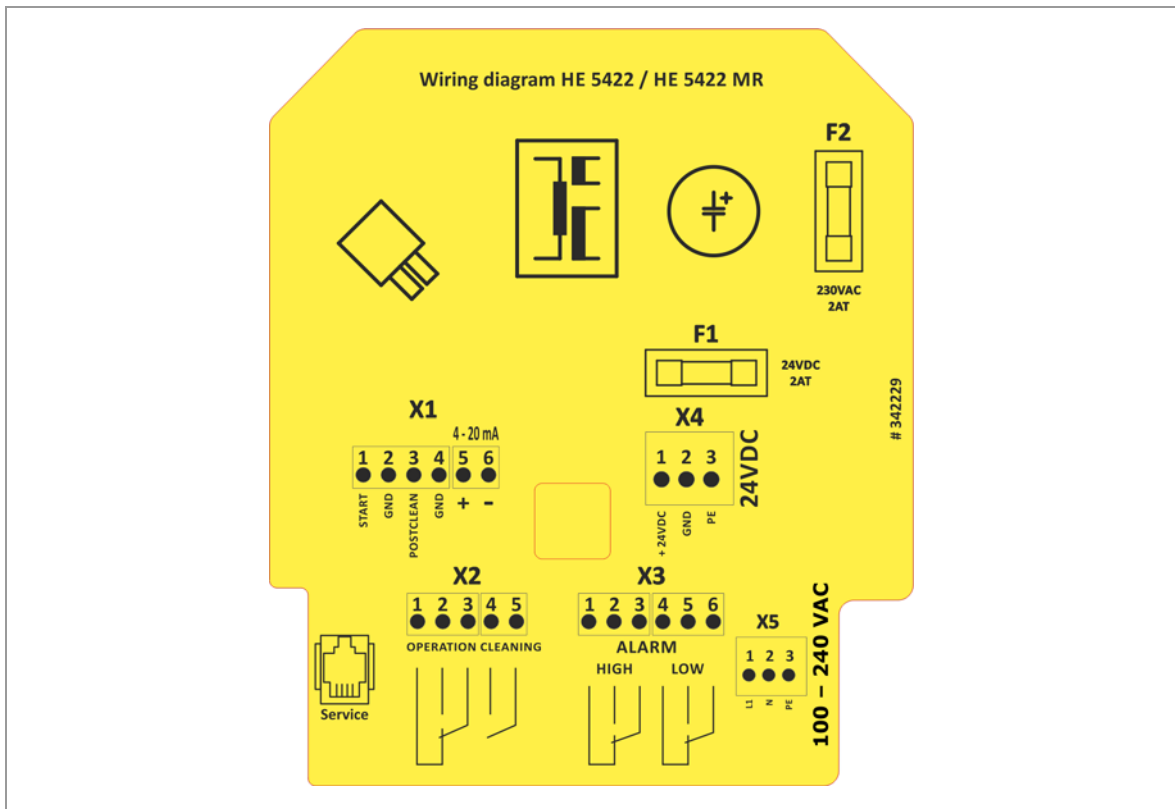

Fig. 5.2: Connection Diagram

5.4 Inputs

The ΔP controller has 2 inputs: Start and Post cleaning. The inputs are internally supplied with + 24 V DC and are active when they are switched to ground (GND) with a potential-free contact.



Note!

The inputs refer to the same ground (-). It is permissible to use one ground wire for both inputs.

5.5 Outputs

Relay

The device is equipped with 4 potential-free relay outputs.

The contacts can each be loaded with 250 VAC / 5 A.

Analogue output

The current differential pressure is reported by a galvanically isolated 4...20 mA signal.

6 Parametrization

6.1 Parametrization using device keyboard



1. Press the PARA button to change the system parameters. A flashing LED indicates the current value to be changed.



2. Select the desired parameter using the UP / DOWN buttons. The respectively current value is indicated on the display.



3. Press the ENTER button to start changing the value of the parameter. The first digit to be changed starts flashing in the display.



4. Press the UP / DOWN buttons to select or change the value of the digit.



5. Press the ENTER button to accept the current value. The next digit will subsequently flash in the display.

6. Repeat steps 4 – 5 until the last digit has been changed. The next parameter is offered.

7. If necessary, change the next parameter.



8. The parametrization mode is exited by pressing the PARA button again.

Main parameter	Setting area	Factory setting
ΔP-Filter [s] Filter constant for the current differential pressure	OFF, 0.2 – 60.0 s	2
Post cleaning time [min] The cleaning relay is closed for the parametrized time for post cleaning purposes.	OFF, 1 – 999 min	10 min
Blowing time [s] During the blowing time, the compressed air is blown into the measuring lines.	1 – 999 s	10 s
Recovery time [s] Delay used to restore the pressure balance after the blowing time.	1 – 999 s	50 s
Interval [min] Waiting time until the next measuring line cleaning cycle.	0 – 999 min	60 min

Main parameter	Setting area	Factory setting
Δp-Measuring range [mbar] <ul style="list-style-type: none"> Is used to convert the current differential pressure into the 4...20mA output signal. 0 mbar = 4 mA Final value of measuring range = 20 mA 	5.0 – 450 mbar	35.0 mbar, 90 mbar, 450 mbar (according the type plate)
High alarm [mbar] <ul style="list-style-type: none"> Threshold for the high-alert message. The relay contact is closed, if the value is exceeded. 	OFF, 0 – 450 mbar	30.0 mbar
Upper threshold [mbar] <ul style="list-style-type: none"> The Δp dependent cleaning starts, if the value is exceeded. Start of the Δp cycle. 	0 – 450 mbar	15.0 mbar
Lower threshold [mbar] <ul style="list-style-type: none"> The Δp dependent cleaning stops, if this value is fallen below of. End of the Δp cycle. 	OFF, 0.1 – 450 mbar	10.0 mbar
Low alarm [mbar] <ul style="list-style-type: none"> Threshold for the low alarm message. When this value is fallen below of, the relay contact is closed, if the post cleaning threshold is not fallen below of within the time frame of the low alarm" delay. 	OFF, -5.0 – 450 mbar	OFF
Post cleaning threshold [mbar] <ul style="list-style-type: none"> The threshold is activated when the lower threshold is exceeded. If the threshold is activated and the pressure falls below the threshold, then the post cleaning cycle is triggered and the cleaning relay for the parametrized post cleaning time is closed. 	OFF, 0 – 450 mbar	2.0 mbar
Δp-Offset [mbar] The offset is added to the currently measured differential pressure.	-50 – 50.0 mbar	0 mbar
Password Protection against unauthorized parameter changes.	0 – 999	0

Chapter 6 Parametrization

The following parameters can only be changed using the "EasyTool Controls" program:

Parameter	Setting area	Factory setting
Δp-Cycles <ul style="list-style-type: none"> Number of Δp-Cycles until the next measuring line cleaning cycle. Alternative to the interval. 	0 – 100	0
Δp-Working range [%] <ul style="list-style-type: none"> Defines the working range below the upper threshold in % of the measuring range. Alternative to the lower threshold. 	1 – 100%	10%
High alarm delay [s] Delay after exceeding the high alarm threshold until the high alarm relay is activated.	1 – 3600 s	0 s
Low alarm delay [s] <ul style="list-style-type: none"> Delay after falling below the low alarm" threshold until the low alarm relay is activated. The relay is not activated, if the post cleaning threshold is fallen below of during this delay period. 	1 – 3600 s	300 s
BG-Cleaning interval [h] <ul style="list-style-type: none"> Monitoring time of the cleaning. If there is no cleaning during the monitoring time, a background cleaning with the parametrized duration is started. 	0 – 99.9 h	0 h
BG-Cleaning duration [s] Duration of the background cleaning.	1 – 3600 s	300 s
Password for parameter protection Protection against unauthorized parameter changes.	0 – 999	0



Note!

The thresholds can be set arbitrarily. There is no logical validation. If the values of the lower threshold are parametrized as higher than the values of the upper thresholds, then the cleaning as well as the pressure display cannot function as expected.

6.2 Offset for zeroing



1. Press the PARA button.



2. Select the "Zeroing" parameter using the UP / DOWN buttons.



3. Confirm using the ENTER button. The display will flash.



4. Press the UP / DOWN buttons simultaneously for 2 seconds. The currently measured value will be inverted and used as the offset.



5. If the UP / DOWN buttons are pressed independently from one another, the offset value can be manually set.

6.3 Parametrization using the Service-PC

When parametrizing multiple devices, it can be advantageous to use the Service-PC for the parametrization. The USB/TTL adapter required for this purpose can be acquired from HESCH. The parameters can be changed using the PC and the "EasyTool Controls" program. A configuration can be saved and a saved (backed-up) configuration can also be restored using this program.

1. Connect the PC to the control unit via USB cable.
2. Start "EasyTool Controls" in order to transfer the files or data.

A manual regarding the most important program functions can be acquired from HESCH.

6.4 Parameter protection



1. When powering up, press the UP / DOWN buttons at the same time for 5 seconds. The display will remain dark for approximately 5 seconds, then "cod" will be displayed, followed by the three-digit password.



2. Press the ENTER button to change the password or abort using the PARA button. If no control action is performed, the program automatically proceeds after 5 seconds.



3. Change the code for the parameter protection using the UP / DOWN buttons.



4. Confirm using the ENTER button.

The code then has to be entered prior to changing a parameter. Other parameter changes are possible until the parametrization mode is exited.

If the current code is supposed to be read out, the UP / DOWN buttons again have to be pressed while powering up. If "0" is selected as code, the parameter protection is deactivated.

6.5 Reset of factory settings



1. Press the PARA and ENTER buttons at the same time while powering up. "EEP" will appear on the display.

2. Hold both buttons for 5 seconds.
With a password > 0, "cod" will flash in the display.



3. Press the ENTER button.



4. Change the code for the parameter protection using the UP / DOWN buttons.



5. Confirm using the ENTER button.

The device has now been reset to factory settings.

7 Operation

7.1 Normal operation

Operation is started by applying supply voltage. The device is controlled by the differential pressure and the inputs of the device.



Note!

All digital inputs of a system refer to the same ground (-). It is permissible to use one ground wire for multiple inputs.

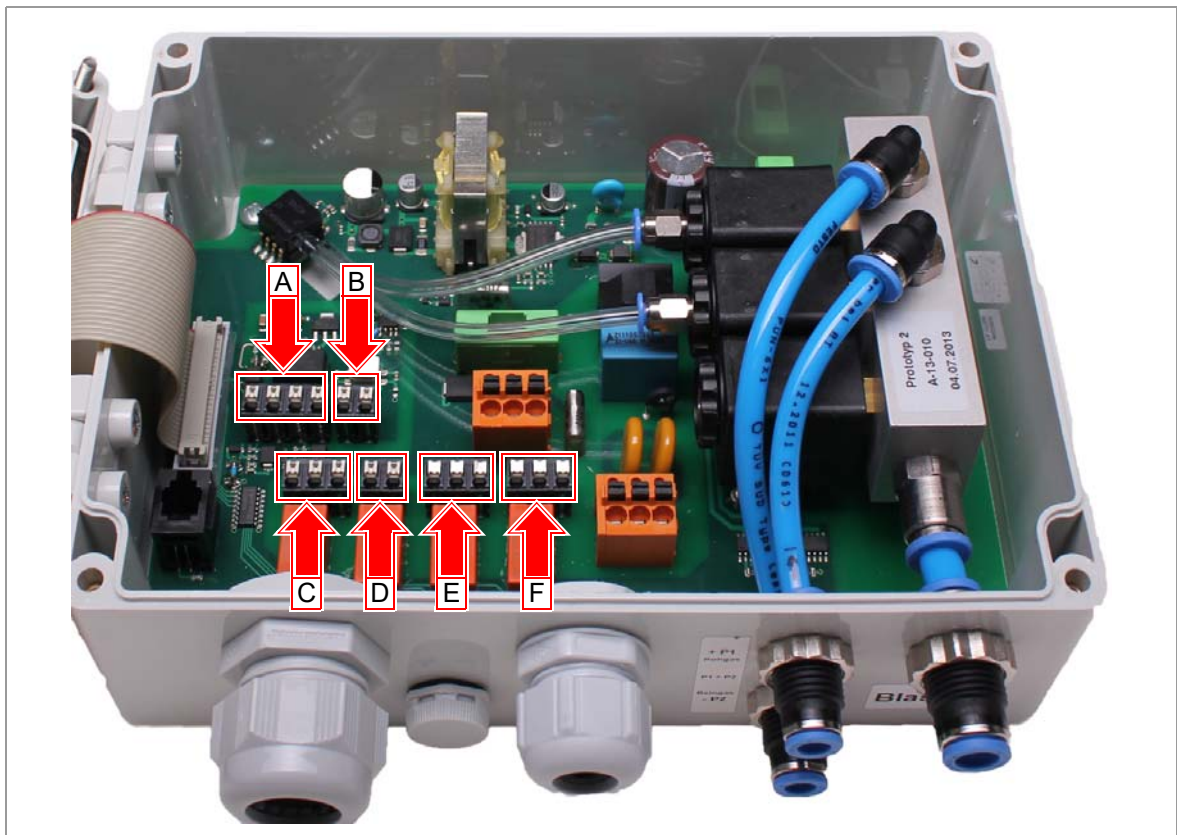







Fig. 7.1: Connection compartment

A			
1	2	3	4
●	●	●	●
START	GND	POSTCLEAN	GND

1. As long as the start input (START) is closed, the cleaning relay is closed.
2. Using a trigger signal on the post cleaning input (POSTCLEAN), the cleaning relay is closed for the configured post cleaning time.

<p>B 4 - 20 mA</p> 	<p>Current output 4...20 mA The current output is galvanically isolated.</p>
<p>C</p> 	<p>Operating or error signal relay. During error-free operation, the NO contact is closed. If a fault has occurred, the NO contact is opened and the NC contact is closed. The following causes will lead to an error message:</p> <ol style="list-style-type: none"> 1. Power failure (Fail-Safe-Operation) 2. Device failure (parameter error) 3. Δp-Sensor fault / measuring range exceedance
<p>D</p> 	<p>Cleaning relay. The cleaning relay is closed when</p> <ol style="list-style-type: none"> 1. The "Upper threshold" is exceeded or the "Lower threshold" is fallen below of 2. The "Post cleaning threshold" is fallen below of for the post cleaning time, if the "lower threshold" was exceeded previously 3. The start input is closed 4. There is a trigger signal on the post cleaning input for the post cleaning time
<p>E</p> 	<p>Δp high alarm relay The relay is closed when exceeding the Δp high alarm threshold. An activation delay can be parametrized.</p>
<p>F</p> 	<p>Δp low alarm relay The relay is closed when the Δp low alarm threshold is fallen below of. An activation delay can be parametrized. The alarm is only active, if the respective value has not fallen below of the post cleaning threshold within the time period of the activation delay.</p>

7.2 Testing function



1. Press the TEST button in order to execute a measuring hose cleaning cycle.

The active test mode is indicated by the lit LED on the TEST button.

7.3 Differential pressure measurement



Fig. 7.2: Connections for differential pressure measurement

The differential pressure is internally measured and passed on to the superordinate control unit or a display device as a 4...20 mA signal. The current output can be scaled across the adjustable measuring range. For example:

0...30 mbar \triangleq 4...20 mA, 0...20 mbar \triangleq 4...20 mA

During normal operation, the cleaning process is started when the upper threshold "Cleaning" is exceeded and is deactivated again when the lower threshold "Cleaning" is reached. In order to execute the post cleaning during a normal deactivation process without triggering an alarm message by falling below the "low alarm", there is a delay time of 5 minutes. The post cleaning threshold has to be reached before these 5 minutes have passed, as the low alarm will else be triggered.

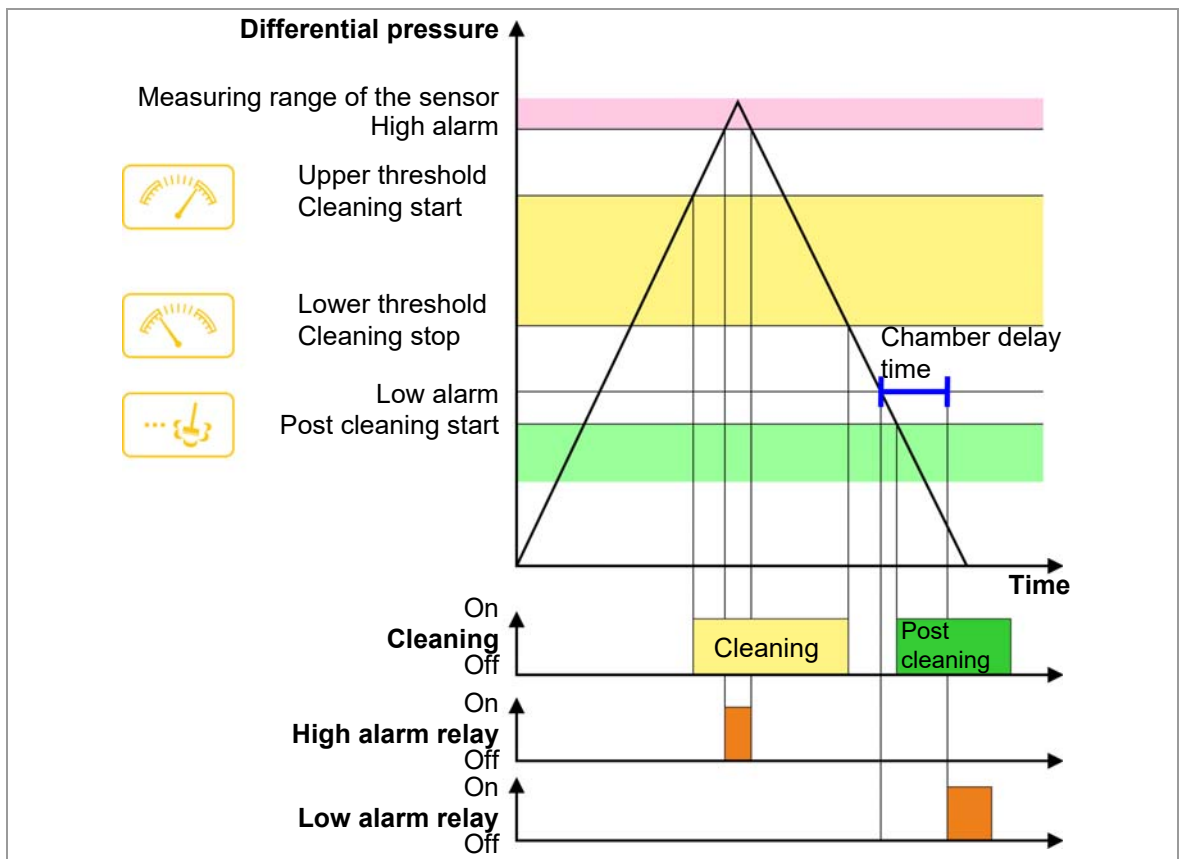

Fig. 7.3: Temporal progression of the differential pressure measurement

7.4 Measuring hose cleaning



Fig. 7.4: Connection for measuring hose cleaning

The measuring hose cleaning system is used to keep the measuring hoses free of dust deposits. For this purpose, the differential pressure measurement is regularly blocked off and compressed air is blown into the connection lines for raw and pure gas. After a recovery time for pressure balancing, the differential pressure measurement is activated again. The process is repeated after a time interval or a number of Δp -Cycles.

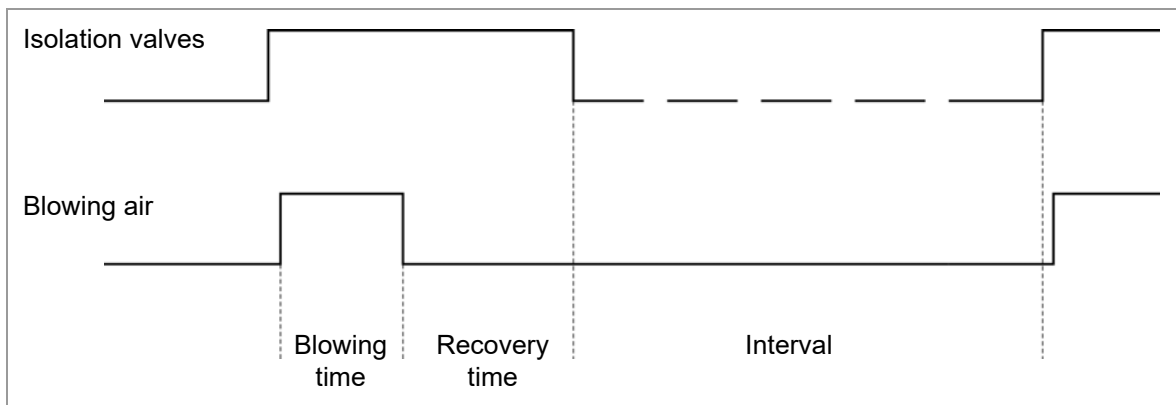

Fig. 7.5: Temporal progression of the measuring hose cleaning

8 Error messages

Display		Cause	Remedy
The differential pressure display shows the following while flashing:		EEPROM Parameter Error	<ul style="list-style-type: none"> Restore factory settings and check parametrization. If this is not successful, send the unit in for repair.
The differential pressure display shows:		The differential pressure signal is below the permissible measuring range	<ul style="list-style-type: none"> Check differential pressure. Check external glands.
The differential pressure display shows:		The differential pressure signal is above the permissible measuring range	<ul style="list-style-type: none"> Check differential pressure signal. Check external glands.
The differential pressure display shows:		Error of the measuring hose cleaning valve 1 (to 3); Interruption	<ul style="list-style-type: none"> Send the device in for repair.
The differential pressure display shows:		Error of the measuring hose cleaning valve 1 (to 3); Over-current	<ul style="list-style-type: none"> Send the device in for repair. Press ENTER for reset the the error message
The high alarm LED flashes.		The differential pressure exceeds the configured threshold	<ul style="list-style-type: none"> Adjust the configured pulse and pause times. Check the filter element. Check the solenoid valves for proper mechanical functioning. Check the compressed air system.
The low alarm LED flashes.		The differential pressure falls below the configured threshold for more than 5 minutes without reaching the post cleaning threshold	<ul style="list-style-type: none"> Adjust the configured pulse and pause times.

HESCH

AUTOMATION PARTNER

EC Declaration of conformity

The Manufacturer:

HESCH Industrie-Elektronik GmbH
Boschstraße 8
31535 Neustadt

declares that the following products:

Item no.	Description	Version 1	Version 2
54221050	Differential Pressure Regulator HE 5422MR	MR adjustable 0-10..0- 35 mbar	100-240 VAC / 24 VDC / 4-20mA
54222050	Differential Pressure Regulator HE 5422MR	MR adjustable 0-10..0- 90 mbar	100-240 VAC / 24 VDC / 4-20mA
54223050	Differential Pressure Regulator HE 5422MR	MR adjustable 0-10..0-450 mbar	100-240 VAC / 24 VDC / 4-20mA

are in conformity with following directives:

- 2006 / 95 / EG Low Voltage Directive
- 2004 / 108 / EG EMC Directive
- 1994 / 9 / EG ATEX Directive of equipment and protective systems intended for use in potentially explosive atmospheres

The following standards are used:

- EN 61010-1:2011 Safety requirements for electrical equipment for measurement, control and laboratory use
- EN 61000-6-2:2006 Immunity for industrial environments
- EN 61000-6-4:2011 Emission standard for industrial environments
- EN 61326-1:2013 Electrical equipment for measurement, control and laboratory use - EMC requirements
- EN 60079-0:2013 Explosive atmospheres
Part 0: Equipment - General requirements
- EN 60079-31:2010 Explosive atmospheres
Part 31: Equipment dust ignition protection by enclosure "t"
Ex tD A22 IP65 T135°C
Ⓢ II 3D Ex tb IIIB T135°C Dc

Neustadt, 14.04.2014

Werner Brandis
Geschäftsführer (CEO)

HESCH
Industrie-Elektronik GmbH
Tel.: +49 (0) 5032 9535-0
Fax: +49 (0) 5032 9535-99
E-Mail: info@hesch.de
Internet: www.hesch.de

Geschäftsführer:
Walter Schröder
Werner Brandis
Amtsgericht Hannover
HRB 111184
Steuer-Nr.: 34/200/22524
UST-Nr.: DE813919106

NORDLB
BLZ 250 500 00
KTO 200 305 282
SWIFT: NOLADE2HXXX
IBAN: DE65 2505 0000 0200 3052 82

Commerzbank Hannover
BLZ 250 400 66
KTO 1 323 732
SWIFT: COBADEFF
IBAN: DE27 2504 0066 0132 3732 00

Bayerische Hypo- und Vereinsbank AG
BLZ 200 300 00
KTO 622 975 506
SWIFT: HYVEDEMM300
IBAN: DE72 200 300 00 0622 9755 06

10 Maintenance and service

10.1 Notes

Maintenance, repair

The device has to be cleaned regularly in order to avoid increased dust build-up on the device.

Disposal

Recycle metals and plastics. Electrical and electronic components should be collected separately and be disposed of accordingly. Properly dispose of printed circuit boards.

Service

HESCH Industrie-Elektronik GmbH
Boschstraße 8
D-31535 Neustadt
Germany
Phone: + 49 (0) 5032 9535-90